

# AVERY DENNISON MARKETING SPECIFICATION

TOLERANCES IN.  $\pm .030$  IN.  
MM  $\pm 0.7$  mm

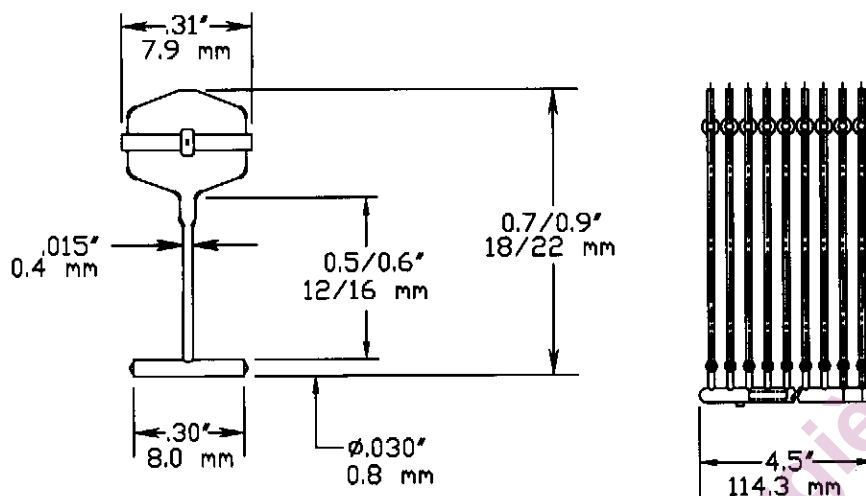

NOT TO SCALE

NOMINAL TENSILE STRENGTH:	4.5/5.5 LBSF / 2.0/2.5 KGF
MATERIAL:	NYLON 6 - WHITE
WEIGHT:	.022 GRAMS/EACH
CLIP QUANTITY:	100
APPLICATION TOOL:	10312 FINE FABRIC PISTOL-GRIP MARK II HAND TOOL (CONTACT LOCAL SALES PERSON FOR INFORMATION ON POWER EQUIPMENT)
PACKAGED:	10,000/CTN, 100,000/CASE
T/F CONN PADDLES:	YES



FASTENER DIVISION  
FITCHBURG, MA 01420 U.S.A.  
TEL. 1-800-225-5913  
FAX. 1-800-848-2169

DESCRIPTION:

3/4" (14 mm) FF Dry Cleaning Paddle

APPROVAL:

*[Signature]* 2-9-09

STOCK NO.

10696

REV

G